



**HOWMET
AEROSPACE**

Howmet Fastening Systems Products



Four Industry-Leading Brands. One High Standard of Quality.

Behind every Howmet Fastening Systems brand is a powerful commitment to providing you the strongest, most reliable fastening solution available, regardless of industry. Our uncompromising approach to engineering, manufacturing quality, and breadth and depth of products is unmatched; resulting in a range of structurally superior fasteners and ergonomically designed installation tooling.

In addition, Howmet Fastening Systems makes the process easy. Our knowledgeable sales and engineering support staff is available to consult with you to help discover the products that best meet your needs and application requirements.

Howmet Fastening Systems stands behind every product and system we provide; you can be sure we'll be there for you today and tomorrow.

For specific, detailed information about the products you see in this catalog, visit hfsindustrial.com

Table of Contents

Introduction	2
HFS Brands	2-3
HuckBolts®	4-5
Huck® Structural Blind Rivets	6-7
Huck Tools	8-9
Marson® Blind Rivets	10-11
Marson Rivet Nuts	12-13
Vaulerivet®	14
Recoil® Threaded Inserts	15-17
Keysert® Inserts and Tools	18-19

Howmet Fastening Systems

Strength and Reliability Across the Board. And Across the Globe.



Precision engineered, designed and manufactured for superior performance, Huck® products include lockbolts, structural blind rivets, hydraulic and pneumatic installation tools, and hydraulic power rigs.



With a wide range of products for specific applications, the Marson® system includes structural blind rivets, non-structural blind rivets and rivet nuts, hand tools, and pneumatic installation tools.



One of the world's most trusted brands of thread inserts, thread repair kits, installation tooling, taps and gauges.



Keyserts® are solid, one-piece, key-locking inserts used to repair damaged threads or for use in original equipment. The Keysert locking keys provide a positive mechanical lock which prevents rotation due to vibration or torsion. Keyserts are available in carbon or stainless steel, both in inch and metric series. Thinwall, Heavy Duty, Extra Heavy Duty, and Solid insert styles are available separately or in kits containing a range of sizes.



For the budget conscious, Howmet Fastening Systems offers its ValueRivet® product line, which includes a broad selection of value-priced rivets, rivet nuts, and manual installation tools.



HuckBolts®

Durable Locking Performance in High Vibration Environments

It's the proven reliable, vibration-resistant locking performance that made Howmet Fastening Systems famous.

You'll find it in every HuckBolt®. Delivering uniform, consistent clamp load and high shear and tensile strength, HuckBolts are ideal for applications ranging from general manufacturing to high-vibration environments such as HVAC, trailer and container assembly, rotating equipment, shopping carts, railroad and transit cars, geodesic structures and many others. HuckBolts also provide a high level of corrosion resistance.

HuckBolts feature an exclusive locking groove design that ensures a tight, permanent fit. In addition to superior fastening performance regardless of which lockbolt type you require, HuckBolts have been proven to reduce labor and installation costs, along with rework and warranty expenses. Stronger, easier to install, and more durable than welding, adhesives, or conventional threaded fastening systems, HuckBolts have been the professionals' choice for decades.

HuckBolt Tooling



Model SF20
SWAGEFORWARD®

Lightweight and technologically advanced, Huck lockbolt tooling makes the installation process quick and easy. For instance, this tool represents our most advanced installation tool yet.

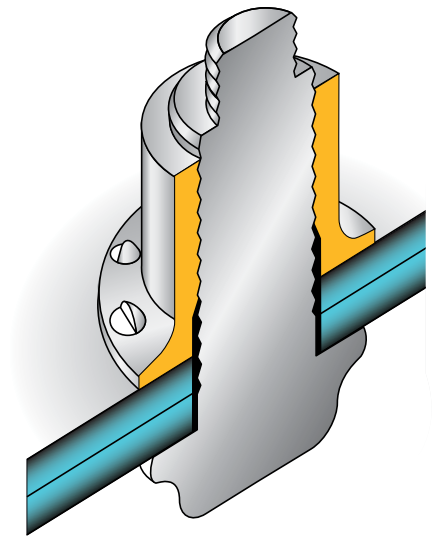

The BobTail® offers a pintail-less design, easy-to-read installation indicator, and collar materials that swage into lockgrooves ensuring a permanent connection.

Types

BobTail®

Huck's swaged-on fastener with no break-off pintail. Corrosion resistant and installs with lightweight ergonomic tooling.

SIZES	1/4" - 3/8", 1/2" - 1" 12MM - 20MM		
MATERIALS	STEEL, ALUMINUM, STAINLESS		
GRADES	GRADE 2	GRADE 5 (CLASS 8.8)	GRADE 8 (CLASS 10.9)



Huck 360®

The engineered nut-and-bolt fastening system with a unique, embedded thread design for vibration-resistance.

SIZES	3/8" - 1-3/8" 12MM - 36MM		
MATERIALS	STEEL		
GRADES	GRADE 8 (CLASS 10.9)		



C50L®

Superior vibration resistance and durability for heavy-duty applications. Meets or exceeds all ASTM A-325 standards for shear, tensile and fatigue life.

SIZES	1/2" - 1-3/8"		
MATERIALS	STEEL, ALUMINUM, STAINLESS		
GRADES	GRADE 5 (CLASS 8.8)	GRADE 8 (CLASS 10.9)	



Magna-Grip®

Vibration-resistant, reliable grade 2 fasteners offering high uniform installed values with a wide grip range.

SIZES	3/16" - 3/8"		
MATERIALS	STEEL, ALUMINUM		



C6L®/C120L/C150L

The classic 6-groove locking fastener ideal for a wide range of applications. Available in grades 2, 5, and 8.

SIZES	3/16" - 3/8"		
MATERIALS	STEEL, ALUMINUM, STAINLESS, STEEL PIN WITH STAINLESS HEAD		
GRADES	GRADE 2	GRADE 5 (CLASS 8.8)	GRADE 8 (CLASS 10.9)



Hucktainer®

Panel fastener that installs with consistent pressure, reducing crushing or crazing.

SIZES	3/8"		
MATERIALS	STEEL		



Huck® Structural Blind Rivets

When High Performance and Holding Power are Critical

Huck Structural Blind Rivets are Howmet's answer to loosening and vibration challenges. And it's the reason they are the world's strongest, most reliable, most consistent blind fastening solution available.

In fact, in fatigue tests, Huck Structural Blind Rivets outlasted the competition by almost 20-to-1. Engineered with a unique locking design, many of the Huck Structural Blind Rivets create an internal lock during installation that virtually eliminates pin pushout by mechanically locking the pin to the sleeve. Each locks permanently, reliably into place, with little effort.

Always accurate and easy to install, Huck Structural Blind Rivets offer quick one-worker installation. Inspections are simple to perform; no need for torque inspections or x-rays.

In applications where vibration resistance, reliability, and strong hold are critical, Huck Structural Blind Rivets offer the strength and durability needed. No fastening system is more dependable.

Sheet-Line Bulb Comparison

Even in minimum-grip applications, Huck fasteners outperform the competition. They're engineered to form a bulb directly on the sheet line, precisely where it's needed, to prevent pull-through.



Auto-Bulb™

Bulb forms directly on sheet line.



The Competition

Bulb forms irregularly above sheet line resulting in lower installed values.

Types

HuckLok®

Wide 1/4" grip range, double-locking action clamps assembly from both sides for maximum joint integrity.

SIZES	3/16", 1/4"
MATERIALS	STEEL
HEADS	PROTRUDING, TRUSS, 100° OVAL COUNTERSUNK

Magna-Lok®

Hole-filling fastener with excellent gap pull-out and moisture resistance. Solid circle lock creates internal lock that virtually eliminates pin push-out. Now available in 1/2" and 316 Stainless Steel.

SIZES	3/16", 1/4", 3/8", 1/2"
MATERIALS	STEEL, ALUMINUM, STAINLESS STEEL, 316 STAINLESS STEEL
HEADS	PROTRUDING, TRUSS, 100° FLUSH

Auto-Bulb™

Features a tapered lead-in point for automated, high-speed assemblies. Forms a bulb directly on the sheet line, preventing pull-through. Available in stainless steel.

SIZES	3/16", 1/4"
MATERIALS	STEEL, STAINLESS STEEL
HEADS	PROTRUDING, COUNTERSUNK

Magna-Bulb®

Unique bulbing fastener with high shear strength offers a broader bearing surface for high pull-out strength in thin materials and/or oversized holes.

SIZES	3/16", 1/4", 5/16"
MATERIALS	STEEL
HEADS	PROTRUDING, TRUSS, 100° OVAL COUNTERSUNK

BOM®

Blind, Oversize, Mechanically locked fasteners. Unique push-&pull installation design for ultimate locking strength from blind-side install.

SIZES	3/16"–3/4"
MATERIALS	STEEL

FloorTight®

Self-countersinking design for consistent installations in plywood and plymetal vehicle floor applications.

SIZES	1/4", 5/16"
MATERIALS	STEEL
HEADS	STANDARD, WIDE FLANGE, PLYMETAL, 90° COUNTERSUNK

Magna-Tite®

Has water-resistant sealant, for oversize holes and repairs. Large blind-side footprint for use in thin or low-strength materials.

SIZES	3/16", 1/4"
MATERIALS	ALUMINUM
HEADS	PROTRUDING, SHAVABLE, LOW PROFILE, 100° OVAL COUNTERSUNK



Huck® Tools

The Industry's Best Installation Tooling

Designed to offer the highest levels of ergonomics, productivity, and long life, the Huck line of installation tooling reflects the same level of innovation and quality as its advanced fasteners. Whether it's a Huck hydraulic tool employed in high-volume installation of large diameter HuckBolts, or a smaller pneudraulic model used to install blind rivets and small diameter HuckBolts, you can count on these tools to deliver the industry's best value.



A Wide Selection of Tooling Options

Huck offers a broad selection of hydraulic and pneumatic tools, in addition to Powerig[®] hydraulic power sources. Huck hydraulic installation tools are available to install a wide range of fasteners, from structural blind rivets to the largest HuckBolts. The Huck line of pneumatic tools, designed for use in repair work or in lower volume production applications, can effectively pull fasteners ranging from 3/32" blind rivets to 3/8" HuckBolts. The new Makita-designed Huck Range Force battery-powered tool has an adjustable pull force and long stroke to enable installation of structural and non-structural rivets and up to 1/4" two-piece HuckBolt[®] fasteners.*

* Excludes 1/4" BOM



Powerig[®] Power Supplies

Combining advanced design and quality manufacturing, Huck Powerigs offer both best-in-class performance and long product life. Whether for mobile or factory use, there is a Huck Powerig hydraulic power source for the job, from electric and gasoline powered portable units, to larger rigs that can individually power up to three tools.



Marson® Blind Rivets

Versatile, Strong, Easy to Install

With nine speciality rivets and three distinct head styles, the Marson® line of blind rivets accommodates almost any application where rivets are used to join two or more pieces of material of varying thicknesses.

Available in a wide array of materials and grip ranges, Marson blind rivets are the fastener of choice for a broad range of general consumer and industrial applications. Products include standard open-end rivets, as well as speciality rivets, including closed-end, multi-grip and plastic rivets.

Benefits of Marson blind rivets include high grip strength with no surface distortion or marred surfaces, low-profile heads, high shear and tensile strength, corrosion resistance, and resistance to tampering and vibration.

In addition, Howmet Fastening Systems can paint colors to match, as well as anodize or plate to your specifications. Strength. Performance. Variety of styles and grip ranges. All reasons why Marson is one of the most recognized and trusted brand names in fasteners, worldwide.

Rivet Installation Tooling

Marson provides professional-grade rivet installation tooling, both manual and pneumatic models. Each is designed for maximum ease of use, high performance, and reliability.



HP-2®/M39000



IF-1/M39075



BT-2A



Big Daddy II

Head Styles



Buttonhead



Large Flange



Countersunk

Marson Rivets are available in a variety of head styles, each engineered to work in specific applications.

Types

Open End

For blind fastening where there is no access to opposite side of work.

SIZES	3/32" TO 1/4"
MATERIALS	STEEL/STEEL, ALUMINUM/ALUMINUM, ALUMINUM/STEEL, STAINLESS/STAINLESS, STAINLESS/STEEL, COPPER/BRASS, COPPER/STEEL



Closed End

Moisture-resistant due to closed end, greater shear and tensile strength.

SIZES	1/8", 1/4"
MATERIALS	ALUMINUM/STEEL, ALUMINUM/ALUMINUM, STAINLESS/STAINLESS



Multi-Grip

Extended grip range capacity, reduces inventory (fewer sizes required).

SIZES	1/8", 3/16"
MATERIALS	ALUMINUM/STEEL, STEEL/STEEL



Tri-Bulb

Large footprint on blind side, great for soft or brittle materials.

SIZES	5/32", 3/16"
MATERIALS	ALUMINUM/ALUMINUM



Q-Lok

Retained mandrel increases shear and tensile strength, use in high vibration applications.

SIZES	3/16"
MATERIALS	STEEL/STEEL



T-Rivets

High clamp up, high shear strength, creates a wide bearing surface.

SIZES	1/4"
MATERIALS	ALUMINUM/STEEL



Special Application

Small flange rivet used primarily for fastening decorative materials on boats, automobiles & other motor vehicles.

SIZES	1/8"
MATERIALS	STAINLESS/STEEL, ALUMINUM/ALUMINUM



Klik-Lock

Hole-filling fastener with excellent gap pull-out. Solid circle lock creates internal lock during installation that virtually eliminates pin push-out.

SIZES	3/16", 1/4"
MATERIALS	STEEL/STEEL, ALUMINUM/ALUMINUM, STAINLESS/STAINLESS



Plastic

Secure lock prevents pull-out, fasten plastic to plastic, plastic to metal or plastic to fiberglass.

SIZES	5MM - 8MM
MATERIALS	NYLON BODY, DELRIN 500 MANDREL



Marson® Rivet Nuts

When High Performance and Strength Are Critical

Marson® Rivet Nuts are designed to deliver low-cost, permanent thread placement in thin material while providing at least six full thread turns per application install. Ideal for painted surfaces, Marson Rivet Nuts help increase production and reduce rework by eliminating the surface damage that can occur with other fastening methods.

Available in a variety of sizes and materials, Marson Rivet Nuts can be used to fasten multiple sheets as well as single sheets. Styles accommodate every type of application, whether it requires heavy push-out loads, counter-sinking, large backside footprint, component mounting or applications requiring a high level of vibration and moisture resistance. Engineered with Howmet Fastening Systems' focus on quality, Marson Rivet Nuts are the ideal choice when high performance and strength are critical.

Rivet Nut Installation Tools & Kits

Marson Rivet Nut Installation Tools and speciality kits provide the operator with the ability to install any size rivet nut or threaded insert with ease. Installation of Marson Rivet Nuts can be completed by one operator with a minimum level of training.



Types

MRN Series

Flathead Flange (thick wall) for applications that require heavy push-out loads (recommend spin-pull tool).

THREAD SIZES	6-32 TO 3/8-16
MATERIALS	STEEL, ALUMINUM



MPN Series

Poly-Nut Rivet Nut, very small flange, lowest profile for near counter sink applications.

THREAD SIZES	6-32 TO 3/8-16, 4MM TO 10MM
MATERIALS	STEEL, ALUMINUM



MTS Series

Thread-Sert®, small flange, 360 degree swaging action in the hole and no maximum grip range.

THREAD SIZES	6-32 TO 3/8-16
MATERIALS	STEEL, ALUMINUM



MLR/MSR Series

Ribbed Rivet Nut with increased turn-out resistance vs. conventional rivet nut; large and small flange available.

THREAD SIZES	6-32 TO 3/8-24, M4x.07 TO M10x1.5
MATERIALS	STEEL, ALUMINUM



MLC/MSC Series

Ribbed Rivet Nut with closed end for thread seal; large and small flange available.

THREAD SIZES	6-32 TO 3/8-24, M4x.07 TO M10x1.5
MATERIALS	STEEL



MHN Series

Large Flange Half Hex Rivet Nut for hex hole to provide exceptional turn-out resistance.

THREAD SIZES	6-32 TO 3/8-16, M4x.07 TO M10x1.5
MATERIALS	STEEL



MQN Series

Quad-Leg Rivet Nut for light duty thin or soft/brittle material — will accommodate slightly oversized hole with large back side footprint.

THREAD SIZES	6-32 TO 1/4-20, M4x.07 TO M6x1.0
MATERIALS	STEEL



MXN Series

Large Flange Cross Bulb, large grip range with pre-bulb and 4 slots, provides large blindside footprint for greater pull-out strength in thin sheet metal and plastics.

THREAD SIZES	1/4-20 TO 3/8-16, 6MM TO 10MM
MATERIALS	STEEL



MET Series

External Thread Stud Rivet Nut allows for component mounting and mate nut.

THREAD SIZES	6-32 TO 3/8-16, 4MM TO 10MM
MATERIALS	STEEL



MNN Series

Neoprene Insert with pre-molded brass nut for quick fastening in vibration and moisture resistant applications.

THREAD SIZES	6-32 TO 1/2-13, M3-0.5 TO M12-1.75
MATERIALS	NEOPRENE



ValueRivet® Rivets and Tooling

Open End Blind Rivets

- For blind fastening where there is no access to opposite side of work
- Simple to install
- Wide variety of head styles and lengths available from 3/32" to 1/4" diameters

Multi-Grip Rivet

- Extended grip range capacity
- Reduces inventory (fewer sizes required)
- Use as a standard open end rivet
- 1/8" to 3/16" diameters

VHR-1/M79000

Hand-Operated Rivet tool

- Sets 3/32"-5/32" diameter rivets in all alloys; 3/16" in steel
- Durable, all-steel construction
- Service wrench and locking tab included



VHR-1X/M79002

Hand-Operated Rivet tool

- Sets 3/32"-5/32" diameter rivets in all alloys; 3/16" in steel
- Extended nosepiece reach of 1-3/4"
- Durable, all-steel construction
- Service wrench and locking tab included



VHR-2/M79032

Hand-Operated Lever tool

- Sets 1/8"-1/4" diameter rivets in all materials
- Can also set T-Rivet/Klik-Split®, Klik-Lock®, Magna-Lok®, Magna-Bulb®, Hemlock®, Tigerbolt®, Ultra-Grip®, Monobolt®, Interlock® and Q-Lok® fasteners



V-2/M79014

Air-Hydraulic tool

- Sets 1/8"-3/16" diameter rivets in all materials
- Pulling force: 1870 lbs; Stroke: .551"
- Recommended airline pressure: 85-95 lbs. Psi. Weight: 3.2 lbs.



V-4/M79060

Air-Hydraulic tool

- Sets 3/32"-1/4" diameter rivets in all materials.
- Pulling force: 3055 lbs.; Stroke: .562"
- Recommended airline pressure: 85-95 lbs. Psi. Weight: 4.2 lbs.



V-3/M79050

Air-Hydraulic tool

- Sets 1/8"-3/16" diameter rivets in all materials
- Pulling force: 1983 lbs.; Stroke: .551"
- Recommended airline pressure: 85-95 lbs. Psi. Weight: 3.2 lbs.



Quality Driven

- Full technical support
- Level I, II, or III PPAPs
- Material certifications available
- Surpasses IFI standards
- Complete offering of rivets and select rivet nuts
- Stocked in choice of bulk or packaged
- Custom designs available
- Wide range of setting tools – both manual and pneumatic

VALUERIVET™ Value Driven

- Technical support available
- PPAPs not available
- No material certifications available
- Conforms to IFI standards
- Limited material and size offering
- Various packaging options available
- Low cost tools available

Recoil® Threaded Inserts

Delivering Positive-Locking Performance

The Recoil® system consists of precision inserts, quality high speed taps, and easy-to-use installation tools which are used for repairing damaged screw threads or creating strong new threads. Recoil helically wound screw-thread inserts are generally manufactured from Type 304 (18-8) stainless steel wire, cold rolled into a diamond shaped cross section. Recoil inserts can be supplied in other materials such as Inconel X750, Inconel 625, Nimonic 90, Nitronic 60, Phosphor Bronze and Type 316 stainless steel.

Recoil inserts are available in either standard free-running form or screw-lock type which provides an internal locking feature. Inserts are manufactured for every thread form including UNC, UNF, BSC, BSW, BSP, BSF, BA, NPT and ISO Metric thread sizes. Inserts are available in 5 different standard lengths. 1D, 1.5D, 2D, 2.5D and 3D. Special lengths are available on request.

Types of Inserts



Free-Running Inserts

The standard Recoil free-running insert provides for easy installation of a female thread, delivering the necessary holding power for most applications. Various sizes available.

Screw-Locking

For particularly demanding or extreme high-vibration applications, Recoil offers a screw-locking design, which provides a superior locking function in the female thread. Various sizes available.



Tangless® Designs

Ideal for a wide range of OEM applications, Recoil Tangless® inserts provide peace-of-mind by eliminating the possibility of foreign objects (the tang) being left behind in the final assembled product. Various sizes available.

Thread Repair Kits

Recoil Repair Kits

A full range of Recoil thread repair kits, covering the majority of sizes commonly in use today, is available from HFS. Recoil industrial kits contain an HSS tap, installation tools, tang break tools, drills, stainless steel inserts, and instructions, in a sturdy reusable container. Recoil problem-solving repair kits are available in single or multiple size format.

Fix-A-Thred Repair Kits

Fix-A-Thred Repair Kits are available in a wide range of sizes for both Unified Inch Coarse (UNC) and Unified Inch Fine (UNF). Kits are available in 33 of the most popular sizes from #8 through 1½" UNC and #10 through 1½" UNF. Metric repair kits are available for coarse and fine threads from M.3 - 5 to M.20 - 25. Each handy plastic kit contains inserts, tap, installation tool and instructions. Individual refill inserts are available as well.



Tooling

Installation Tooling

Howmet Fastening Systems also offers a selection of work arms and power tooling, including high-efficiency pneumatic, electric and battery installation tools for in-line production or repetitive maintenance situations. A range of associated tooling is available to facilitate insert installation, including manual installation tooling and manual, spring, and pneumatic operated tang break off tools.



New Tooling Options



The REC-20 is a lightweight, portable battery powered driver for small production and hard-to-reach tapped hole applications. Operates either vertically or horizontally in two speeds. Use for Recoil Tanged and Tangless® insert sizes M2 – M6” or #2-56 – ¼”.



REC-10K with air motor includes small and large adaptors to fit Recoil Front End Assemblies (FEA) from M2.5 to M16 or #2-56 – 5/8”, and an adaptor to suit ¼” hex drive mandrels. The air regulator, lubricator and gauge help clean the air and govern the amount of lubricant for the air motor.



The REC-12US Electric Driver is designed for low or high volume production environment and used for Recoil Tanged and Tangless bulk or strip feed products.

Taps and Gauges

Optimum results can be achieved with Recoil taps and gauges to suit hand-tapping through to volume production requirements. Using the “Go-No-Go” gauge, tapped holes can be gauged to enable a precision fit.



Keysert® Inserts

Ideal For Heavy-Wear and Positive Mechanical Lock

Keyserts are solid, one-piece, key-locking inserts used to repair damaged threads or for use in original equipment. The Keysert locking keys provide a positive mechanical lock which prevents rotation due to vibration or torsion. Keyserts are available in carbon or stainless steel, both in inch and metric series. Thinwall, Heavy Duty, Extra Heavy Duty, and Solid insert styles are available separately or in kits containing a range of sizes. Installation tools are also available separately or in a range kit.

Key Locking Inserts Features

- Installed with standard drills and taps
- Easy installation
- May be used in multiple materials including aluminum, magnesium and cold rolled steel
- Easy to remove



Thin Wall

Ideal for repairing damaged threads. Different material thicknesses are available depending on application (see other types).

SIZES	#10 – 1/2" INTERNAL THREAD 5/16" – 5/8" EXTERNAL THREAD
MATERIALS	INSERTS - C1215 OR EQUIVALENT (CARBON); 303 STAINLESS STEEL (STAINLESS)
KEYS	INSERTS WITH INTERNAL THREAD SIZE 5/16" OR M7 AND LARGER ARE FURNISHED WITH 4 LOCKING KEYS. KEYS MADE FROM 302 STAINLESS STEEL.

Heavy Duty

Similar to Thin Wall Keyserts with a thicker wall for applications where more strength is required.

SIZES	#8 – 1-1/2" INTERNAL THREAD 5/16" – 1-7/8" EXTERNAL THREAD
MATERIALS	INSERTS - C1215 OR EQUIVALENT (CARBON); 303 STAINLESS STEEL (STAINLESS)
KEYS	INSERTS WITH INTERNAL THREAD SIZE 5/16" OR M7 AND LARGER ARE FURNISHED WITH 4 LOCKING KEYS. KEYS MADE FROM 302 STAINLESS STEEL.

Extra Heavy Duty

Extra Heavy Duty Keyserts are preferred when:

- Extra strength/torque out is required
- The parent material has sufficient space for a heavier wall
- Larger hole needs to be reduced to a smaller size

SIZES	#6 – 1" INTERNAL THREAD 5/16" – 1-1/2" EXTERNAL THREAD
MATERIALS	INSERTS - C1215 OR EQUIVALENT (CARBON); 303 STAINLESS STEEL (STAINLESS)
KEYS	INSERTS WITH INTERNAL THREAD SIZE 5/16" OR M7 AND LARGER ARE FURNISHED WITH 4 LOCKING KEYS. KEYS MADE FROM 302 STAINLESS STEEL.

Solid

Solid threaded inserts are perfect for:

- Relocating holes that have been drilled or tapped in the wrong place
- Plugging holes or filling in holes that are too big

SIZES	5/16" – 1-3/8" EXTERNAL THREAD
MATERIALS	INSERTS - C1215 OR EQUIVALENT (CARBON); 303 STAINLESS STEEL (STAINLESS)
KEYS	INSERTS WITH INTERNAL THREAD SIZE 5/16" OR M7 AND LARGER ARE FURNISHED WITH 4 LOCKING KEYS. KEYS MADE FROM 302 STAINLESS STEEL.

Pneumatic Keysert® Tooling

Characteristics

- The hydro-pneumatic Power Tool 3352PTC-1 is designed to install metric Keyserts from sizes M5 to M12, the slightly bigger 3352PTC-2 has a larger stroke to install M5 to M24 sized Keyserts. A specific nosepiece is required for each size.
- Individual adjustments can be made using the integrated force control depending on size of the Keysert and hardness of the surrounding material.
- One button operation allows for quick, consistent, and reliable installation.
- The hydro-pneumatic system is low maintenance, ergonomic and lightweight.
- Both tools can install Keyserts into alloys, light materials, steel and cast iron up to a maximum of 30 HRC or 1000 MPa.





**HOWMET
AEROSPACE**

Howmet Fastening Systems

Industrial Division Brands



Huck, Marson, Recoil, Keysert, Camloc, Simmonds and Snep are trademarks of Howmet Aerospace Inc. and/or its subsidiaries.

North America

Waco Operations

PO Box 8117
8001 Imperial Drive
Waco, TX 76714-8117
Tel: +1 800-388-4825
Fax: +1 800-798-4825
hfs.sales.waco@howmet.com

Kingston Operations

1 Corporate Drive
Kingston, NY 12401
Tel: +1 800-278-4825
Fax: +1 845-334-7333
hfs.sales.kingston@howmet.com

Tracy Operations

1925 North MacArthur Drive
Tracy, CA 95376
Tel: +1 800-826-2884
Fax: +1 800-573-2645
hfs.sales.idg@howmet.com

Global

Telford Operations

Unit C, Stafford Park 7
Telford, Shropshire
England TF3 3BQ
Tel: +44 (0) 1952-290011
Fax: +44 (0) 1952-290459
thisales@howmet.com

Suzhou Operations

58 Yinsheng Road,
SIP Suzhou, Jiangsu
215126 China
Tel: +86-512-62863800-8888

Melbourne Operations

1508 Centre Road
Clayton, Victoria
Australia 3168
Tel: +613-8545-3333
Fax: +613-8545-3390
hfs.sales@howmet.com

Tokyo Operations (Japan & Korea)

1013 Hibiya U-1 Bldg.
Uchisaiwai-cho 1-1-7
Chiyoda-ku, Tokyo
100-0011 Japan
Tel: +81-3-3539-6594
Fax: +81-3-3539-6585

hfsindustrial.com

[YouTube.com/HFSIndustrial](https://www.youtube.com/HFSIndustrial)

The information contained in this publication is only for general guidance, and is not intended to create any warranty, express, implied, or statutory; all warranties are contained only in Howmet Fastening Systems' written quotations, acknowledgments, and/or purchase orders. It is recommended that the user secure specific, up-to-date data and information regarding each application and/or use of such products.

© 2020 Howmet Aerospace Inc. All rights reserved. HFS6772 0120
Auto-Bulb, Value-Rivet, HuckBolt, Klik-Split, Klik-Lock, Magna-Bulb, Magna-Bulb,
Q-Lok, Fix-A-Thred, Swageforward, BobTail, Huck 360, C50L, Magna-Grip, C6L,
Hucktainer, HP-2, Thread-Sert, HuckLok, BOM, FloorTight, Magna-Tite and Powerig,
are trademarks of Howmet Aerospace Inc. and/or its subsidiaries.